

## TECHNICAL DATASHEET AFTC HA7308 - 0.031" THICK

### PRODUCT DESCRIPTION

Heat Activated products are constructed of two different adhesive systems. One side consists of a hotmelt adhesive that is inactive at ambient temperatures. In application to extruded EPDM or TP seals, this adhesive is activated by a heat source. This activated adhesive then melts together with the extruded rubber seal forming a very strong and permanent bond. The other side of the heat activated tape consists of a pressure sensitive adhesive. Here you will typically find the same adhesive system as the one used in the Automotive series.

### TYPICAL APPLICATIONS

- Glass
- Glass/epoxy
- Stainless steel
- Galvanized steel
- Anodized steel
- Coated aluminum

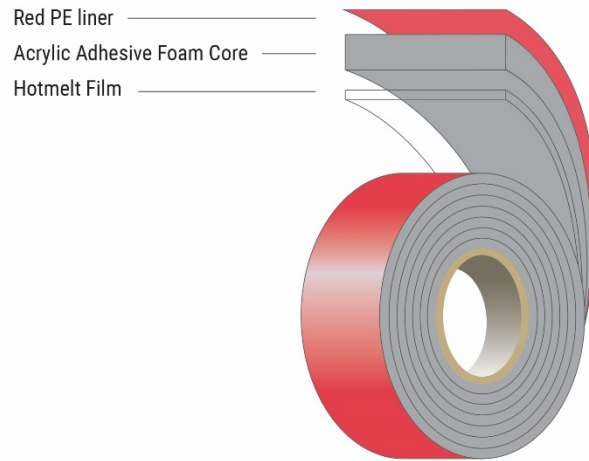

### PRODUCT FEATURES & BENEFITS

- UV resistant
- Solvent resistant

TECHNICAL DATA	VALUE	TEST METHOD / STANDARD
<b>THICKNESS</b>	0.031" ±10%	
<b>COLOR</b>	Gray	
<b>MATERIAL / SUBSTRATE</b>	Uncoated Acrylic Foam	
<b>CORE</b>	Acrylic Adhesive Foam Core	
<b>ADHESIVE TYPE</b>	Hotmelt Film	
<b>ADHESIVE SYSTEM</b>	Permanent Adhesive	
<b>ADHESIVE SIDE</b>	Double Sided Adhesive	
<b>LINER</b>	Red PE liner	
<b>DENSITY</b>	52 lb/ft <sup>3</sup>	
<b>MINIMUM TEMPERATURE RESISTANCE</b>	-40°F	
<b>SHORT-TERM TEMPERATURE RESISTANCE</b>	374°F	
<b>LONG-TERM TEMPERATURE RESISTANCE</b>	248°F	
<b>90° PEEL ADHESION</b>	12 lb/in	ASTM D3330
<b>DYNAMIC SHEAR STRENGTH</b>	92 lb/in <sup>2</sup>	ASTM D1002
<b>TENSILE STRENGTH</b>	92 lb/in <sup>2</sup>	ASTM D897
<b>STATIC SHEAR STRENGTH @ 72°F</b>	1,000 grams*	ASTM 3654
<b>STATIC SHEAR STRENGTH @ 150°F</b>	500 grams*	ASTM 3654
<b>STATIC SHEAR STRENGTH @ 200°F</b>	500 grams*	ASTM 3654
<b>CELL STRUCTURE</b>	Closed Cell	
<b>SOLVENT RESISTANCE</b>	Excellent	
<b>UV RESISTANCE</b>	Excellent	

Specifications are believed to be accurate at the time of publication and are subject to change without notice. It is the responsibility of the end-user to test and determine suitability of this material for a particular application. **REV. 0**

**TECHNICAL DATASHEET AFTC HA7308 - 0.031" THICK**

<b>RECOMMENDED APPLICATION TEMPERATURE</b>	Minimum 59°F	
--	--------------	--

**NOTES:** \*Weight that 1/2 square inch will hold 10,000 minutes (7 days).

<b>SHELF LIFE/STORAGE</b>	
<b>SHELF LIFE</b>	18 months
<b>RECOMMENDED STORAGE CONDITIONS</b>	Store in its original package and in a dry place between 39.2°F and 100.4°F

**CLEANING**

To clean your light and medium contaminated substrates, use an isopropanol/alcohol solution (IPA). When cleaning your substrate, a tear free, light colored paper towel is required. Wipe the substrate in one direction using the one cloth method (one cloth with cleaner) or a two-cloth method (one cloth with cleaner and one dry cloth to follow) is acceptable if you are short on time. Repeat these steps until your cloth is clean and free of any contaminants. For heavily contaminated substrates, use a cleaning agent such as MEK, Heptan or Acetone. These cleaning agents may leave a residue which would have to be removed using the IPA cleaner.

**ABRASION**

When bonding to raw aluminum, abrading of the surface is a must. The oils used in the waltzing of the aluminum are pressed into the pores of the material. To remove these oils, that will influence the bond, we recommend using abrasive pads to ensure the proper level of abrasion without damaging your substrates. Besides raw aluminum, abrading is a method utilized to help improve your bond. After the abrasion process is completed, remove any residue using an IPA cleaner following the methods mentioned above.

**PRIMER**

The use of a primer is recommended when bonding to some low surface energy substrates. Examples include, different types of polymers, powder coated metals, or porous materials such as wood, cork, stone or concrete. Primers are also used to help speed up your production process. The AFTC line can take up to 72 hours to reach its end-strength. The use of a primer ensures the end-strength will be achieved within 20 minutes. H-O Products offers two primers; the primer 33 and the primer 101. Determining which one of these primers is suitable for your application ultimately depends on the substrates and environmental influences.

**PRESSURE**

AFTC tapes are pressure sensitive adhesives. Therefore, a minimum amount of pressure is required on the bond line to ensure the maximum adhesion to your substrates. This pressure should be applied in a rolling fashion. A hand roller or mechanical presser are the preferred methods. The pressure on the bond line must be a minimum of at least 14.5 psi.

Specifications are believed to be accurate at the time of publication and are subject to change without notice. It is the responsibility of the end-user to test and determine suitability of this material for a particular application. **REV. 0**